

EXHIBITOR SERVICE MANUAL



MERCHANDISE SHOW

AUGUST 30 - 31, 2011

RIVER ROCK RESORT & CASINO





PROFESSIONAL SHOW SERVICES

Dear Exhibitor,

RE: 2011 PGABC MERCHANDISE SHOW

Show In Motion Professional Show Services is pleased to have been appointed as the official show service supplier for the 2011 PGABC Merchandise Show. We welcome you as an exhibitor in this event, and we look forward to working with you to ensure that your participation in this event is successful.

This Exhibitor Service Kit contains information and lease order forms for the most commonly requested display and electrical items. **If you have any requirements not listed on these forms please contact us.** Please review these pages carefully. If we are to serve you effectively it is important that these forms be completed correctly and returned to us promptly.

Each exhibit booth will be supplied with the following courtesy of Show Management;

- 8' high drape back wall
- 4' high drape side wings
- 1 – 2' x 6' covered & skirted display table
- 2 side chairs
- Booth carpet

Please note that electrical service is not provided with the standard booth package. Should your exhibit require any electrical service for you must complete the attached Electrical Lease order form and return it to us.

Also, please note that if you are shipping any display material, boxes, etc. to this event you must complete and return the attached Materials Handling order form. All shipments must be sent to the advance warehouse at the address shown on the enclosed "Materials Handling" form.

Material arriving at the advance storage warehouse without a completed Materials Handling form will not be delivered to your booth.

SHIPMENTS DIRECT TO SHOW SITE ARE NOT PERMITTED AND WILL BE REFUSED.

We realize that exhibiting in a trade show can be complicated. Please do not hesitate to call us with any questions or concerns. We look forward to serving you at the 2011 PGABC Merchandise Show.

21 - 8528 - 123 STREET
SURREY - BC
CANADA - V3W-3V6

PHONE 604-599-1440
FAX 604-599-1438

11625 - 115TH. STREET
OSOYOOS - BC
CANADA - V0H-1V5

PHONE 250-495-5025
FAX 250-495-5026



CONTACT SHEET

HOW TO REACH US:

- TELEPHONE - (250) 495-5025
- FACSIMILE - (250) 495-5026

For Rental Inquiries Please Contact
Anissa Hume (anissa@showinmotion.com)

For Shipping Inquiries Please Contact
Brian Huggan (brian@showinmotion.com)

For Electrical Inquiries Please Contact
Brad Riznek (brad@showinmotion.com)

MAILING ADDRESS:

11625 - 115th. Street
Osoyoos, BC, V0H-1V5

ADVANCED SHIPPING ADDRESS:

"Your Company Name"
PGABC MERCHANDISE SHOW
c/o Show In Motion
21 - 8528 - 123 Street
Surrey, BC, V3W-3V6

EXHIBITOR PAYMENT POLICY

1. **All orders for services from Show In Motion must be accompanied by (1) a completed Credit Card Authorization form and (2) a photocopy of both the front and back of the credit card being supplied. NO EXCEPTIONS. We regret that we will not accept or process any orders that omit any of the above information.**
 2. **ELIGIBILITY FOR DISCOUNT PRICING**
To qualify for the discount pricing offered for this event payment in full must accompany your order and be received in our offices prior to the date shown in the bottom left corner of each order form. Purchase orders do not qualify for discount pricing.
 3. **SHOW SITE ORDERS**
All services ordered at the show must include payment in full at the time that the order is placed.
 4. **MATERIALS HANDLING**
If you are shipping any material to this event you must complete both the Materials Handling order form and the Credit Card Authorization Form. All freight must be shipped to Show In Motion at the address shown on the enclosed "Materials Handling" order form.
- SHIPMENTS DIRECT TO SHOW SITE ARE NOT PERMITTED AND WILL BE REFUSED.**
- Please ensure that all shipments are sent "Prepaid" including all applicable taxes, duties, surcharges, etc. Any charges billed to Show In Motion by your carrier following the event will be charged to the Credit Card number provided along with a \$ 100.00 service charge.
5. **POST EVENT STORAGE**
All freight returned to either the Show In Motion or advanced storage warehouse following the event to await pick up by the Exhibitor Appointed Carrier will incur both Outbound Freight service charges and storage charges at standard industry rates.
 6. All prices shown in this service manual are in Canadian dollars.
 7. All materials and equipment are supplied on a rental basis for the duration of the show and remain the property of Show In Motion. All rentals include delivery, installation and removal from your booth.
 8. It is understood and agreed that the exhibitor is responsible for the care, custody and control of all materials and equipment provided by Show In Motion and accepts full responsibility for any loss or damage to the equipment until it is returned to Show In Motion.
 9. **LABOR PROVIDED UNDER SHOW IN MOTION SUPERVISION**
Show In Motion shall be responsible for the performance of labor provided under this option. Show In Motion will not be liable for loss or damage caused by delay in labor beginning work when exhibitor requests labor to begin later than the start of the working day.
 10. **LABOR PROVIDED UNDER EXHIBITOR SUPERVISION**
Exhibitor shall be responsible for the performance of labor provided under this option. The exhibitor shall supervise labor secured through Show In Motion in a reasonable manner to prevent bodily injury and/or property damage. It is the exhibitors' responsibility to check in with the Show In Motion Service Desk to collect labor, and to return to Service Desk to release labor when the work is completed.
 11. **CANCELLATIONS**
All requests to cancel orders and for refunds must be made in writing no less than 7 full business days prior to Show In Motion's scheduled move-in. All cancellations are subject to a minimum 50% cancellation fee. Any cancellations made within 7 full business days of Show In Motion's scheduled move-in will be subject to a 100% cancellation fee.
 12. **CLAIM(S) FOR LOSS**
Exhibitor agrees that any and all claims for loss must be submitted to Show In Motion, in writing, immediately at show site, and in any case, no later than the conclusion of the exhibit. Exhibitor understands and agrees that all claims made after the conclusion of the exhibit will be rejected.
 13. Any check returned to us for any reason and / or any declined credit card number will be subject to a service charge of \$ 100.00 for payment reprocessing.
 14. Show In Motion "Terms and Conditions", "Payment Policy" and "Electrical Terms & Conditions" are subject to change at the sole discretion of Show In Motion and without notice to any parties.



TRADE SHOW TIPS

As your trade show partner, our intention is to provide you with efficient, hassle-free service, allowing you to get on with your show. Even if you are using an Exhibitor Appointed Contractor (EAC), you will undoubtedly need to order basic services, including Materials Handling, from us and should have a working knowledge of this Exhibitor Service Manual contents and information.

We hope that by following the information below your participation in this event will be successful.

ORDERING TRADE SHOW SERVICES

Please complete the Credit Card Authorization form as required. We regret that we are unable to process any order received without this form, even if paying by company check or wire transfer. Your credit card would then be charged only in the event of showsite orders placed by your representatives. All orders for services must be accompanied by a photocopy of both the front and back of the card as well as photocopy of the cardholders picture identification.

Ensure that all forms are completed as thoroughly as possible at the time that you are placing your order. We realize that shipping information including waybill numbers, carrier, etc. are sometimes not available at the time of placing your order and these details can certainly be forwarded to us as they become available closer to the show.

When ordering carpeting, tables, counters, etc., please remember to include your color preferences.

INBOUND FREIGHT / MOVE-IN

Confirm inbound shipping addresses as detailed in this manual and direct your freight accordingly. Inbound freight sent to an incorrect advance storage warehouse will incur additional surcharges.

Ensure that you have your carriers waybill number and contact information, including after hours and weekend phone numbers available.

After emptying crates, etc., place "Empty" labels on all sides of your crates and cases. Do not place "Empty" labels on your crates until you are prepared to have them removed as once they are removed from your booth we may not be able to return them to you until the show is over.

SHOW SITE

Ensure that you, or your representative, has on-hand copies of all show service order forms.

Put together a small "survival kit" shipped with your exhibit including any required tools for assembling your booth, packing tape, Velcro, box cutter, pens and markers.

Do not hesitate to contact our representatives at the Show Service Centre, located in the exhibit hall, with any questions or concerns. We are here to help make your show a success.

OUTBOUND / MOVE-OUT

Keep in mind that the return of your empty crates and cases can take from 2 to 12 hours depending on the size of the show, and coordinate your outbound flight to accommodate this.

Remember that all exhibit material must be completely removed from the exhibit hall within 4 hours following the close of the exhibits. Freight left beyond this time will be forced to the Show In Motion warehouse.



TERMS & CONDITIONS OF CONTRACT

PLEASE READ CAREFULLY! YOU ARE ENTERING A CONTRACT WHICH MAY LIMIT YOUR POSSIBLE RECOVERIES IN CASE OF LOSS OR DAMAGE. The terms and conditions set forth below are part of the contractual agreement between Show In Motion and you, the EXHIBITOR, who accepts the terms and conditions of this contract once any of the following are met;

The Credit Card Authorization form is signed; OR the Materials Handling Agreement is signed; OR the Exhibitors materials are delivered by a carrier to either the Show In Motion warehouse, an advanced storage warehouse OR a show site where Show In Motion is the official show contractor; OR an order for labor and / or rental equipment is placed with Show In Motion; OR when work is performed on behalf of the Exhibitor by Show In Motion.

DEFINITIONS;

For purposes of this contract, Show In Motion means Show In Motion (SIM), Vancouver Display (VDS), and their employees, agents, officers, and related entities including but not limited to any subcontractors that SIM may appoint. The term "EXHIBITOR" means the Exhibitor, its employees, agents, representatives, and any Exhibitor Appointed Contractor (EAC).

PAYMENT FOR SERVICES;

Customer shall be liable for all unpaid charges for services performed by SIM or Agents. Customer authorizes SIM to charge their credit card directly for services rendered on its behalf after departure, by placing an order either in advance or on site with SIM. Orders received without full advanced payment or after the deadline date, as noted on each order form, will incur additional charges. In the event of any dispute between Exhibitor and SIM relative to any loss, damage or claim, such Exhibitor shall not be entitled to and shall not withhold payment, or any partial payment, due to SIM relative to any services, as an offset against the amount of any alleged loss or damage. Any claim against SIM shall be considered a separate transaction and shall be resolved on its own merits. SIM reserves the right to charge Exhibitor for the difference between the Exhibitors estimate of charges and the actual charges incurred by the Exhibitor, or for any charges that SIM may be obligated to pay on behalf of the Exhibitor including, but not limited to, any shipping charges.

CREDIT TERMS;

All charges are due prior to service being performed. SIM has the right to require prepayment at the time of request for services. A failure to pay timely will result in Exhibitor having to pay in cash in advance for future services. SIM is authorized to charge Exhibitor credit card for any unpaid charges for services provided to Exhibitor including charges for return shipping. Any charges not paid within 30 days of delivery of service will be subject to interest at a rate of 2% per month until paid in full.

INBOUND AND OUTBOUND SHIPMENTS;

Consistent with standard industry practices, there may be a lapse of time between the delivery of shipments to the booth and the arrival of the EXHIBITOR as well as a lapse of time between the completion of packing by the Exhibitor and the actual pick up of materials from the booth for loading on to outbound carrier. During such times, the materials will be left unattended. SIM will not be held responsible or liable for any loss, damage, theft or disappearance of materials after same have been delivered to EXHIBITORS booth or before same have been picked up for reloading at the conclusion of the event.

Inbound freight shipped to the incorrect advance storage warehouse will incur additional charges consistent with Outbound Freight rates, terms and conditions.

PACKAGING & CRATES;

SIM shall not be responsible for damage to loose, uncrated materials, pad wrapped or shrink wrapped, materials, glass breakage, concealed damage, carpets in bags or poly or materials improperly packed. In addition, SIM shall not be responsible for crates and packaging which are unsuitable for handling, in poor condition or have prior damage. Crates and packaging should be of a design to adequately protect contents for handling by forklift or similar means.

FORCED FREIGHT;

SIM will not be liable for exhibit material not picked up by Exhibitors chosen carrier by the show deadline. It is the exhibitors sole responsibility to complete accurate paperwork for shipping and ensure that all material is properly labeled. Exhibitor acknowledges that it is a lessee of space, and as such has an obligation to remove its goods prior to the targeted time. If exhibit material remains on the exhibit floor beyond this point SIM has the right to remove them in order to restore the premises to its original condition for show management pursuant to the venue's lease with show management. All forced freight will be returned to SIM warehouse and will be subject to Outbound Freight Service charges as detailed in this service manual and storage charges at standard industry rates.

DESIGNATED CARRIERS;

In order to expedite removal of materials from show site, SIM shall have the authority to change designated carriers if the carrier designated by EXHIBITOR does not pick up shipment(s) within 4 hours following close of exhibits. Where no disposition is made by EXHIBITOR, materials will be taken to SIM warehouse to await EXHIBITOR shipping instructions and EXHIBITOR agrees to be responsible for charges related to re-routing and handling. **IN NO EVENT SHALL SIM BE RESPONSIBLE OR LIABLE FOR ANY LOSS RESULTING FROM SUCH RE-ROUTING.** EXHIBITOR hereby agrees and understands that the carriers terms and conditions apply to their shipment and material once it has been accepted by said carrier. **SIM WILL NOT BE RESPONSIBLE OR LIABLE FOR FAILURE TO PROVIDE THESE CARRIER TERMS AND CONDITIONS TO THE EXHIBITOR.**

DISPOSAL OF GOODS;

SIM retains the right to dispose of goods left in our warehouse more than sixty (60) days following the event without liability.

EMPTY CONTAINERS;

Empty container labels will be available from the show site service desk. Affixing labels to the containers is the sole responsibility of EXHIBITOR. All previous labels should be removed or obliterated. SIM assumes no responsibility for; Error in above procedures, removal of containers with old empty labels, removal of containers without SIM empty labels, improper information on empty labels. SIM assumes no liability for loss or damage to goods or crates, or the contents therein, while containers are in storage.

SHOW IN MOTION TERMS AND CONDITIONS AND PAYMENT POLICY ARE SUBJECT TO CHANGE AT THE SOLE DISCRETION OF SHOW IN MOTION WITHOUT NOTICE TO ANY PARTIES.

SIM'S RESPONSIBILITIES;

SIM shall be responsible only for those services which it directly provides. SIM assumes no responsibility for any persons, parties or other contracting firms not under SIM'S direct supervision and control. SIM shall not be responsible for any loss or damage due to strike, lockouts, work stoppages, natural elements, vandalism, acts of God, civil disturbances, power failure, explosion or any other circumstance over which it has no control.

INDEMNIFICATION;

EXHIBITOR agrees to indemnify, forever hold harmless and defend SIM and their employees, officers and agents from and against any and all demands, claims, causes of action, fines, penalties, damages (including consequential), liabilities, judgements and expenses (including but not limited to reasonable attorneys' fees and investigation costs) on account of personal injury or death, damage to or loss of property or profits arising out of, or contributed to, by any of the following;

- EXHIBITOR'S negligent supervision of any labor secured through SIM, or the negligent supervision of such labor by any of EXHIBITOR'S employees, agents, representatives, customers, invitees and/or any Exhibitor Appointed Contractor (EAC);
- EXHIBITOR'S negligence, willful misconduct, or deliberate act, or the negligence, willful misconduct, or deliberate act of EXHIBITOR'S employees, agents, representatives, customers, invitees, and/or any (EAC) at the show or exposition to which this contract relates, including but not limited to the misuse, improper use, unauthorized alteration, or negligent handling of SIM'S equipment;
- EXHIBITOR'S violation of federal, provincial or local ordinances;
- EXHIBITOR'S violation of Show Regulations and/or Rules as published and set forth by facility and/or Show Management.

INSURANCE;

It is understood that SIM is not an insurer. Any insurance shall be obtained by EXHIBITOR in amounts and for perils determined by EXHIBITOR. EXHIBITOR agrees to provide SIM with a release and waiver of subrogation to the extent of any insurance settlement received.

CLAIM(S) FOR LOSS;

EXHIBITOR understand and agrees that any and all claims for loss or damage must be submitted, in writing, to SIM immediately at show site, and in any case, no later than the conclusion of the show. For purposes of claim reporting the "conclusion" of the show shall be construed as the time when EXHIBITOR'S materials are delivered to the carrier for transportation from show site. EXHIBITOR agrees and understands that all claims after this time shall be rejected.

MAXIMUM RECOVERY;

If found liable for any loss, SIM'S sole and exclusive MAXIMUM liability for loss or damage to EXHIBITOR'S materials and EXHIBITOR'S sole and exclusive remedy is limited to repair or replacement of like kind and quality, subject to a dollar amount limit equal to the amount paid by EXHIBITOR to SIM for material handling services during the show or exposition under this contract.

MISCELLANEOUS;

EXHIBITOR, as a material part of the consideration to SIM for material handling services, waives and releases all claims against SIM, its' employees, agents and officers with respect to all matters for which SIM has disclaimed liability pursuant to the provisions of this contract. The EXHIBITOR acknowledges that he or she has read this agreement, understands it and agrees to be bound by its terms, and further agrees that it is the complete and exclusive agreement between the parties. The invalidity or unenforceability of any provision hereof shall not affect, modify or impair the validity and enforceability of all other provisions herein.

BREACH OF CONTRACT AND / OR NEGLIGENCE ONLY;

SIM'S liability shall be limited to any loss or damage which results solely from SIM'S negligence in the actual physical handling of the items comprising EXHIBITOR'S shipment(s) OR which results from BREACH OF THIS CONTRACT and not for any other type of damage or loss. In no event shall SIM be liable to the exhibitor or to any other party for special, collateral, exemplary, indirect, incidental or consequential damages, whether such damages occur either prior to, subsequent to or are alleged as a result of tortious conduct, failure of the equipment or services of SIM or breach of any of the provisions of this agreement regardless of the form of action, whether in contract or in tort, including strict liability and negligence, even if SIM has been advised or has notice of the possibility of such damages, or for any damages caused by EXHIBITOR'S failure to perform EXHIBITOR'S responsibilities. Such excluded damages include, but are not limited to, loss of profits, loss of use or business interruption, or other consequential or indirect economic loss(es).

JURISDICTION;

THIS CONTRACT SHALL BE CONSTRUED UNDER THE LAWS OF THE PROVINCE OF BRITISH COLUMBIA WITHOUT GIVING EFFECT TO ITS CONFLICT OF LAWS RULES.

**EXHIBIT MATERIAL
DO NOT DELAY
RUSH !**

EXHIBITING
COMPANY:

SHIP TO: C/O SHOW IN MOTION
21 - 8528 - 123 STREET
SURREY, BC, CANADA
V3W-3V6
(TEL) 604-599-1440
(FAX) 604-599-1438

RE: PGABC MERCHANDISE SHOW

BOOTH # : _____

CARRIER : _____

NUMBER _____ OF _____



TELEPHONE: (250) 495-5025
 FACSIMILE: (250) 495-5026



MERCHANDISE
 SHOW

**CREDIT CARD
 AUTHORIZATION**

IF YOU ARE USING THE SERVICES OF SHOW IN MOTION, THIS FORM MUST BE COMPLETED AND RETURNED TOGETHER WITH A PHOTOCOPY OF BOTH THE FRONT AND BACK OF THE CREDIT CARD.
 NO ORDERS WILL BE ACCEPTED UNLESS ALL INFORMATION IS PROVIDED.
 BY SIGNING THIS FORM YOU AGREE THAT YOUR ORDER WILL BE GOVERNED AND BOUND BY BOTH THE SHOW IN MOTION PAYMENT POLICY AND TERMS AND CONDITIONS OF CONTRACT AS SPECIFIED IN THE EXHIBITOR MANUAL AND HAVE ADVISED YOUR SHOW SITE REPRESENTATIVE(S) ACCORDINGLY.

WE WILL USE THIS AUTHORIZATION TO CHARGE YOUR CREDIT CARD ACCOUNT FOR ADVANCE ORDERS AND ANY ADDITIONAL AMOUNTS INCURRED AS A RESULT OF SHOWSITE ORDERS PLACED BY YOU OR YOUR REPRESENTATIVE. THESE CHARGES MAY INCLUDE LABOR, MATERIALS HANDLING OR ANY CHARGES WHICH SHOW IN MOTION MAY BE OBLIGATED TO PAY ON YOUR BEHALF INCLUDING, WITHOUT LIMITATION, ANY SHIPPING CHARGES.

WE RESERVE THE RIGHT TO ADJUST ORDERS NOT CALCULATED CORRECTLY.

THIS COMPLETED FORM MUST ACCOMPANY ALL OTHER COMPLETED SERVICE REQUEST FORMS.

COMPANY: _____ BOOTH #: _____
 ADDRESS: _____ PHONE #: _____
 CITY & PROVINCE: _____ FAX #: _____
 POSTAL / ZIP CODE: _____ EMAIL: _____

PLEASE COMPLETE CLEARLY THE FOLLOWING INFORMATION;

MASTERCARD VISA AMERICAN EXPRESS

ACCOUNT NUMBER

EXPIRATION DATE _____ CCV CODE _____

I, _____ of _____ do
 (Cardholder name) (Exhibiting Company)

hereby authorize Show In Motion Services, Inc. to charge my credit card for expenses related to the above named event. I understand that the total amount of the charges to my credit card is subject to final verification by Show In Motion at the conclusion of the event allowing for my estimation of labor and / or materials handling charges and / or pre-show discounts. I further understand and agree that, as the representative for the exhibiting company, I am ultimately responsible for payment of all charges and agree to be bound by all terms and conditions as described on this form and the Payment Policy Form.

BILLING ADDRESS: _____

CARDHOLDERS SIGNATURE: _____

YOUR SIGNATURE DENOTES ACCEPTANCE OF ALL TERMS & CONDITIONS INCLUDED IN THIS SERVICE MANUAL.



MERCHANDISE SHOW

ATTENTION ALL EXHIBITORS

Show management has appointed Show In Motion as the exclusive providers of materials handling and drayage services for this event.

The operation or use of all mechanical material handling equipment including hand trucks, dollies and pallet jacks, is not permitted by exhibitors or their appointed contractors.

The operation or use of all motorized lifting equipment for installation of booth structures or signs is not permitted by exhibitors or their appointed contractors.



ALL MATERIALS HANDLING EQUIPMENT, LIFTS AND MANPOWER MUST BE PROVIDED BY SHOW IN MOTION.

Thank you for your understanding and complete cooperation.



TELEPHONE: (250) 495-5025
 FACSIMILE: (250) 495-5026



MERCHANDISE
 SHOW

MATERIALS HANDLING ORDER FORM

Show In Motion, is the exclusive materials handling contractor for this event. If you are shipping any material to this event it is compulsory that you complete this form and return it to us. We will receive your display material up to 21 days prior to move-in. All shipments must be sent prepaid. WE WILL NOT ACCEPT COLLECT SHIPMENTS. Material must be received not less than 7 full business days prior to the show to avoid surcharges.

SHIPMENTS DIRECT TO SHOW SITE ARE NOT PERMITTED AND WILL BE REFUSED.

SERVICE INCLUDES;

- Receiving and advance storage of your display material up to 21 days prior to show dates.
- Transport of your display material to show site and delivery of material, crates and boxes directly to your booth.
- Removal and storage of empty boxes and crates during show.
- Return of empty boxes and crates to your booth following the show.
- Re-loading of display material on to outbound carrier(s) from show site.

| | |
|-------------------------------|-----------------|
| Crated or Skidded Shipment | \$.75 / Pound |
| Special Handling Shipment | \$.90 / Pound |
| Uncrated or Pad Wrap Shipment | \$ 1.05 / Pound |

RATES

- Minimum charge of \$ 200.00
- Unmarked freight will be cubed at 30 pounds per cubic foot.

DEFINITIONS OF SERVICE;

CRATED: Exhibit material that is skidded or is in any type of shipping crate that unloaded at dock height with no additional handling required.

UNCRAVED: Exhibit material that is shipped loose or pad wrapped, and / or unskidded machinery.

SPECIAL HANDLING: Exhibit material delivered in such a manner that it requires additional handling such as ground level unloading, stacked or constricted space unloading, designated piece unloading, loads mixed with pad wrapped material, multiple shipments, carpet and / or pad only shipments and shipments that require additional time, equipment or labor to unload. FEDEX, UPS, Purolator and DHL are included in this category due to their delivery procedures.

When recording weight you must round up to the next one hundred (100) pounds. Example 445 lbs = 500 lbs.

Shipments arriving from different carriers and / or on different dates and times will be billed individually.

Dimensional or cubic weight will be charged where applicable.

Rates are based on incoming weight only.

SHIPPING ADDRESS: # 21 - 8528 - 123 STREET, SURREY, BC, V3W-3V6

| | | | |
|---|----------------------|-------------------------|-----------------------|
| MATERIAL SHIPPED FROM (CITY) | | CARRIER | PRO OR WAYBILL NUMBER |
| DATE SHIPPED | # OF CRATES OR SKIDS | # OF BOXES | TOTAL # OF PIECES |
| CUSTOMS BROKER | | TOTAL WEIGHT | |
| COMPANY: _____ CONTACT: _____ BOOTH #: _____ | | POST DEADLINE - ADD 30% | |
| | | SUB-TOTAL | |
| | | 12 % HST | |
| | | TOTAL | |

ALL ORDERS ARE GOVERNED BY SHOW IN MOTION PAYMENT POLICY AND TERMS AND CONDITIONS OF CONTRACT.

**STANDARD RATES WILL BE APPLIED
 TO ALL ORDERS NOT RECEIVED AND
 PAID IN FULL PRIOR TO:
 AUGUST 8, 2011**

**YOUR COMPLETED CREDIT
 CARD AUTHORIZATION FORM
 MUST ACCOMPANY THIS
 ORDER FORM.**



TELEPHONE: (250) 495-5025
 FACSIMILE: (250) 495-5026



MERCHANDISE
 SHOW

**PRIORITY EMPTY
 RETURN ORDER FORM**

Depending on the size of the show and the logistics of the facility, the standard return time for crates, containers and cases can be anywhere from 2 - 12 hours.

This service provides for the expedited Priority Return of your empty containers.

Exhibitors ordering this service can expect their crates and other empties returned to their booth within 30 minutes of the close of show.

This service must be ordered prior to your empty containers being removed from the exhibit floor and entered in to storage.

If you would like to take advantage of this service, please complete the information below and return this form to Show In Motion.

| RATES | PRICE PER CONTAINER | PRICE PER CONTAINER |
|---------------------------------------|---------------------|---------------------|
| | Discount Rate | Standard Rate |
| Priority Empty Container Return | \$ 50.00 | \$ 65.00 |
| Estimated Number of Pieces..... _____ | | |

PLEASE NOTE THAT THIS SERVICE CANNOT BE ORDERED ONCE YOUR EMPTY CONTAINERS HAVE BEEN REMOVED FROM THE EXHIBIT HALL FOR STORAGE.

| | |
|--------------|--|
| SUB-TOTAL | |
| 12 % HST | |
| TOTAL | |

COMPANY: _____
 CONTACT: _____
 BOOTH #: _____

**STANDARD RATES WILL BE APPLIED TO ALL ORDERS NOT RECEIVED AND PAID IN FULL PRIOR TO:
 AUGUST 8, 2011**

YOUR COMPLETED CREDIT CARD AUTHORIZATION FORM MUST ACCOMPANY THIS ORDER FORM.



TELEPHONE: (250) 495-5025
 FACSIMILE: (250) 495-5026



MERCHANDISE
 SHOW

**OUTBOUND FREIGHT
 SERVICE ORDER FORM**

OUTBOUND FREIGHT ORDER FORM

In accordance with the storage and freight policies of both the facility and this event, all outbound freight must be shipped directly from show site immediately following the close of the exhibit.

If this policy is inconvenient for you and / or your carrier we are pleased to offer you the option of having your exhibit material returned to our warehouse to await pick-up from your carrier at a convenient time during normal business hours.

If you would like to order this service please complete the required information below and return this form to Show In Motion along with your other service request forms.

This service is offered in conjunction with our standard Materials Handling Service. You must complete and return the attached Materials Handling Order Form as well.

RATES

\$.45 / Pound - Pre-Deadline Rate
 \$ 150.00 Minimum Charge
 20% Fuel Surcharge
 Rates Based on Incoming Weight

PICK-UP INFORMATION

ADDRESS: 21 - 8528 - 123 STREET
 SURREY, BC, V3W-3V6
 HOURS: 9:00 AM - 4:00 PM (PACIFIC TIME)
 MONDAY - FRIDAY

PLEASE NOTE THAT EXHIBIT MATERIAL REMAINING ON SITE BEYOND THE DESIGNATED MOVE-OUT TIME WILL BE FORCED TO OUR WAREHOUSE AT THE ABOVE PREVAILING RATES.

PLEASE NOTE THAT YOU MUST MAKE PICK-UP ARRANGEMENTS WITH YOUR CARRIER. UNLESS ARRANGED IN ADVANCE WE WILL NOT CONTACT YOUR CARRIER TO COORDINATE THE PICK-UP.

ESTIMATED WEIGHT
ESTIMATED SUB TOTAL
POST DEADLINE (ADD 30%)
20% FSC
SUB-TOTAL
12 % HST
TOTAL

| |
|--|
| |
| |
| |
| |
| |
| |
| |

COMPANY: _____
 CONTACT: _____
 BOOTH #: _____

**STANDARD RATES WILL BE APPLIED TO ALL ORDERS NOT RECEIVED AND PAID IN FULL PRIOR TO:
 AUGUST 8, 2011**

YOUR COMPLETED CREDIT CARD AUTHORIZATION FORM MUST ACCOMPANY THIS ORDER FORM.



TELEPHONE: (250) 495-5025
FACSIMILE: (250) 495-5026



MERCHANDISE
SHOW

**BOOTH CLEANING
ORDER FORM**

As the official service contractor, Show In Motion has exclusive jurisdiction over all cleaning services. This jurisdiction prohibits other service contractors including exhibitor appointed contractors from providing these services. The cleaning services provided by the exhibit hall include a general sweeping of the aisles only. All carpets ordered from Show In Motion will be installed in clean condition, however you may wish to order cleaning service prior to show opening to remove any debris caused during set-up. Cleaning service required during the event and within your booth space may be ordered below.

100 Square Foot Minimum Charge

STANDARD BOOTH CLEANING

TOTAL SQUARE FEET _____ X NUMBER OF DAYS _____ X \$.50 = \$ _____

BOOTH CLEANING FIRST DAY ONLY

TOTAL SQUARE FEET _____ X 1 DAY X \$.75 = \$ _____

PORTER SERVICE

TOTAL SQUARE FEET _____ X NUMBER OF DAYS _____ X \$ 1.05 = \$ _____

POST DEADLINE RATE (ADD 30%) - \$ _____

CALCULATE 12 % HST ON ABOVE TOTAL - \$ _____

TOTAL COST - \$ _____

Our standard booth cleaning service includes daily vacuuming of carpet, emptying of wastepaper baskets, general cleaning and dusting of exhibit and furnishings.

Our porter service includes emptying of wastepaper baskets, wipe down of counters and removal of glasses and coffee cups at 2 hour intervals.

COMPANY: _____

CONTACT: _____

BOOTH #: _____

**STANDARD RATES WILL BE APPLIED
TO ALL ORDERS NOT RECEIVED AND
PAID IN FULL PRIOR TO:
AUGUST 8, 2011**

**YOUR COMPLETED CREDIT
CARD AUTHORIZATION FORM
MUST ACCOMPANY THIS
ORDER FORM.**



**MERCHANDISE
SHOW**

**COMPUTER & A/V
ORDER FORM**

**TELEPHONE: (250) 495-5025
FACSIMILE: (250) 495-5026**

| ITEM | PRICE | PRICE | QUANTITY | AMOUNT |
|---|-----------------------------|-----------------------------|----------|--------|
| | Discount Rate Daily Rate | Standard Rate Daily Rate | | |
| PROJECTION | | | | |
| XGA Projector, 2600 Lumens (please call for brighter options) | 400.00 | 520.00 | | |
| Projection Screen 4' 5' 6' (please call for larger options) | 50.00 | 65.00 | | |
| 42" Black Skirted A/V Cart | 50.00 | 65.00 | | |
| FLAT SCREEN MONITORS (FOR VIDEO & COMPUTER) | | | | |
| 20" LCD Monitor | 100.00 | 130.00 | | |
| 28" Monitor / DVD Player | 150.00 | 195.00 | | |
| 27" LCD Monitor (16:9 Ratio) | 200.00 | 260.00 | | |
| 32" LCD Monitor 16:9 Ratio) (1920 x 1080) | 250.00 | 325.00 | | |
| 42" LCD Monitor 16:9 Ratio) (1920 x 1080) | 400.00 | 520.00 | | |
| 52" LCD Monitor 16:9 Ratio) (1920 x 1080) | 600.00 | 780.00 | | |
| Monitor Floor Stand (for use with monitors 32" and larger only) | 80.00 | 104.00 | | |
| FLAT SCREEN MONITORS (FOR COMPUTER ONLY) | | | | |
| 17" LCD (3:4 Ratio) (1024 x 1280) | 100.00 | 130.00 | | |
| 20" LCD (16:9 Ratio) (1024 x 1280) | 130.00 | 170.00 | | |
| 32" LCD 16:9 Ratio) (1920 x 1080) | 300.00 | 390.00 | | |
| Tower Speakers (for plasma screen) | 75.00 | 98.00 | | |
| VIDEO PLAYERS | | | | |
| DVD Player Multi Zone | 70.00 | 91.00 | | |
| Blu Ray Disc Player | 150.00 | 195.00 | | |
| COMPUTER SYSTEMS (Monitor Not Included) | | | | |
| P4 - 6g, 2 MB, 20x CD / DVD Burner, Windows 7 Desktop | 150.00 | 195.00 | | |
| P4 - 2.8g, 2 MB, 20x CD/DVD Burner, Windows 7 Desktop | 200.00 | 260.00 | | |
| P4 - 3.0, 1g, 30GB, CD / DVD rw / fw, WiFi, 15.4" Laptop | 250.00 | 325.00 | | |
| Friendlyway Interactive Kiosk with 17" Touchscreen | 450.00 | 585.00 | | |
| PRINTERS | | | | |
| HP LaserJet p4014, 45 PPM, 1200 x 1200 dpi, 256MB Ram | 150.00 | 195.00 | | |
| HP Color LaserJet CP3525n, 30ppm, 1200 x 600 dpi, 1GB Ram | 200.00 | 260.00 | | |
| Premium Laser Printer Paper (500 sheets) | 15.00 | 20.00 | | |

Custom Audio and Visual Packages Available on Request - Please Call Us.

LABOR \$ 50.00

SUB-TOTAL

12 % HST

TOTAL

COMPANY: _____
 CONTACT: _____
 BOOTH #: _____

**STANDARD RATES WILL BE APPLIED
TO ALL ORDERS NOT RECEIVED AND
PAID IN FULL PRIOR TO:
AUGUST 8, 2011**

**YOUR COMPLETED CREDIT
CARD AUTHORIZATION FORM
MUST ACCOMPANY THIS
ORDER FORM.**



TELEPHONE: (250) 495-5025
 FACSIMILE: (250) 495-5026



MERCHANDISE
 SHOW

**EXHIBIT INSTALLATION
 ORDER FORM**

| | | |
|--------------------|---|--|
| REGULAR TIME | 8:00 A.M. - 4:00 P.M. - WEEKDAYS | \$ 60.00 / HR. |
| OVERTIME | 4:00 P.M. - 6:00 P.M. - WEEKDAYS 8:00 A.M. - 4:00 P.M. - SATURDAYS | \$ 70.00 / HR. |
| DOUBLE TIME | ALL OTHER HOURS INCLUDING SUNDAYS & HOLIDAYS | \$ 82.00 / HR. |
| SUPERVISORY CHARGE | 25% OF LABOR TOTAL | <input type="checkbox"/> REQUIRED <input type="checkbox"/> NOT REQUIRED |

INSTALLATION (ESTIMATED REQUIREMENTS):
 DATE: _____ START TIME DESIRED: _____
 NUMBER OF MEN REQUESTED: _____ ESTIMATED NUMBER OF MAN HOURS : _____
 ESTIMATED INSTALLATION CHARGES: \$ _____

DISMANTLE (ESTIMATED REQUIREMENTS):
 DATE: _____ START TIME DESIRED: _____
 NUMBER OF MEN REQUESTED: _____ ESTIMATED NUMBER OF MAN HOURS : _____
 ESTIMATED INSTALLATION CHARGES: \$ _____

- SUPERVISORY CHARGES WILL APPLY UNLESS THERE IS A REPRESENTATIVE FROM YOUR COMPANY IN ATTENDANCE DURING BOTH INSTALLATION AND DISMANTLING.
- MINIMUM CHARGE OF 1 (ONE) MAN HOUR. LABOR THEREAFTER IS CHARGED IN ONE-HALF (1/2) HOUR INCREMENTS.
- ALL WORK WILL BE DONE ON REGULAR TIME WHEN POSSIBLE
- YOU MUST REPORT TO SHOW IN MOTION SERVICE DESK TO COLLECT YOUR LABOR IF EXHIBITOR SUPERVISED.

TOTAL ESTIMATED CHARGES

**25% SUPERVISION CHARGE
 (\$ 35.00 Minimum)**

POST DEADLINE + 30%

SUB-TOTAL

12 % HST

TOTAL

| |
|--|
| |
| |
| |
| |
| |
| |

COMPANY: _____
CONTACT: _____
BOOTH #: _____

**STANDARD RATES WILL BE APPLIED
 TO ALL ORDERS NOT RECEIVED AND
 PAID IN FULL PRIOR TO:
 AUGUST 8, 2011**

**YOUR COMPLETED CREDIT
 CARD AUTHORIZATION FORM
 MUST ACCOMPANY THIS
 ORDER FORM.**



COMPANY NAME: _____

BOOTH NUMBER: _____

PLEASE COMPLETE THE FOLLOWING INFORMATION IF YOUR DISPLAY IS TO BE SET-UP AND / OR DISMANTLED BY SHOW IN MOTION AND YOU WILL NOT BE PRESENT TO SUPERVISE THE INSTALLATION AND / OR DISMANTLE.

INBOUND SHIPPING INFORMATION

CARRIER: _____ CARRIER PHONE #: _____
SHIPPED TO: WAREHOUSE _____ SHOW SITE _____ FROM (CITY/STATE): _____ DATE SHIPPED: _____
TOTAL NUMBER OF: CRATES _____ CARTONS _____ OTHER (SPECIFY): _____

SET-UP INFORMATION

SETUP PLAN / PHOTO: ATTACHED _____ SENT WITH EXHIBIT _____ IN CRATE # _____
CARPET: WITH EXHIBIT _____ RENTED FROM SHOW IN MOTION _____ COLOR _____ SIZE _____
ELECTRICAL PLACEMENT: DRAWING ATTACHED _____ WITH EXHIBIT _____ ELECTRICAL UNDER CARPET _____
COMMENTS: _____
GRAPHICS: WITH EXHIBIT _____ SHIPPED SEPERATELY _____ CARRIER _____
COMMENTS: _____
SPECIAL TOOLS / HARDWARE REQUIRED: _____

OUTBOUND SHIPPING INFORMATION:

SHIP TO: _____
METHOD: COMMON CARRIER _____ AIR FREIGHT _____ VAN LINE _____ OTHER (Specify) _____
CARRIER (If Known): _____
FREIGHT CHARGES: PREPAID _____ COLLECT _____ ACCOUNT # _____

PLEASE PROVIDE AN EMERGENCY CONTACT:

NAME: _____ PHONE # _____



TELEPHONE: (250) 495-5025
 FACSIMILE: (250) 495-5026



MERCHANDISE
 SHOW

**CARPET & PADDING
 LEASE ORDER FORM**

32 OZ. DESIGNER SELECT CARPET

Guaranteed new, premium quality carpet.
 Available in a variety of designer colors.
 Price includes delivery, installation, taping and removal.
 A surcharge will be applied for any damage after installation.

- Black Pewter Charcoal Royal Blue
 Navy Emerald Peacock Berry
 Red Burgundy Purple White

Booth Size: _____' x _____' = _____ Square Feet

*** 100 SQUARE FOOT MINIMUM ***

| PRICE Discount Rate | PRICE Standard Rate | QUANTITY | AMOUNT |
|------------------------|------------------------|----------|--------|
| \$ 3.25 (Sq. Ft.) | \$ 4.20 (Sq. Ft.) | | |

20 OZ. STANDARD CARPET

Available in five standard colors.
 Price includes delivery, installation, taping and removal.
 A surcharge will be applied for any damage after installation.

- Silver Blue Forest Green
 Purple Red

Booth Size: _____' x _____' = _____ Square Feet

*** 100 SQUARE FOOT MINIMUM ***

| PRICE Discount Rate | PRICE Standard Rate | QUANTITY | AMOUNT |
|------------------------|------------------------|----------|--------|
| \$ 2.25 (Sq. Ft.) | \$ 2.90 (Sq. Ft.) | | |

5/8" REBOND FOAM PADDING

Price includes delivery, installation and removal.
 Booth Size: _____' x _____' = _____ Square Feet
 *** 100 SQUARE FOOT MINIMUM ***

| PRICE Discount Rate | PRICE Standard Rate | QUANTITY | AMOUNT |
|------------------------|------------------------|----------|--------|
| \$ 1.90 (Sq. Ft.) | \$ 2.45 (Sq. Ft.) | | |

VISQUEEN PLASTIC COVERING

Price includes delivery, installation and removal.
 Booth Size: _____' x _____' = _____ Square Feet
 *** 100 SQUARE FOOT MINIMUM ***

| PRICE Discount Rate | PRICE Standard Rate | QUANTITY | AMOUNT |
|------------------------|------------------------|----------|--------|
| \$ 1.00 (Sq. Ft.) | \$ 1.30 (Sq. Ft.) | | |

COMPANY: _____
 CONTACT: _____
 BOOTH #: _____

| | | | |
|------------------|--|--|--|
| SUB-TOTAL | | | |
| 12 % HST | | | |
| TOTAL | | | |

**STANDARD RATES WILL BE APPLIED
 TO ALL ORDERS NOT RECEIVED AND
 PAID IN FULL PRIOR TO:
 AUGUST 8, 2011**

**YOUR COMPLETED CREDIT
 CARD AUTHORIZATION FORM
 MUST ACCOMPANY THIS
 ORDER FORM.**

NO ORDERS WILL BE PROCESSED UNTIL PAYMENT IS MADE IN FULL



TELEPHONE: (250) 495-5025
 FACSIMILE: (250) 495-5026



MERCHANDISE
 SHOW

**TABLES & CHAIRS
 LEASE ORDER FORM**

| DISPLAY ITEMS | PRICE | PRICE | QUANTITY | AMOUNT |
|---------------|---------------|---------------|----------|--------|
| | Discount Rate | Standard Rate | | |

| DISPLAY ITEMS | PRICE Discount Rate | PRICE Standard Rate | QUANTITY | AMOUNT |
|---|------------------------|------------------------|----------|--------|
| TABLES & RISERS | | | | |
| Covered & Skirted Display Table (2' X 4') | \$ 65.00 | \$ 85.00 | | |
| Covered & Skirted Display Table (2' X 6') | 77.00 | 100.00 | | |
| Covered & Skirted Display Table (2' X 8') | 84.00 | 109.00 | | |
| 4th. Side Of Table Skirted | 35.00 | 45.00 | | |
| Extension To 40" Height - Add | 35.00 | 45.00 | | |
| Unskirted Display Table | 50.00 | 65.00 | | |
| Blue, Teal, Green, Red, Black, Silver, Purple, Gold or White (Circle Preference) | | | | |
| 30" Round Pedestal Table - 28" High with White Linen | 65.00 | 85.00 | | |
| 30" Round Pedestal Table - 28" High with Black Linen | 70.00 | 91.00 | | |
| 30" Round Bistro Table - 40" High with White Linen | 75.00 | 98.00 | | |
| 30" Round Bistro Table - 40" High with Black Linen | 80.00 | 104.00 | | |
| 30" Round Coffee Table - 17" High with White Linen | 60.00 | 78.00 | | |
| 30" Round Coffee Table - 17" High with Black Linen | 65.00 | 85.00 | | |
| Table Risers - 8" high X 6" deep X 72" long | 30.00 | 39.00 | | |
| CHAIRS | | | | |
| Executive High Back Swivel Chair (Black Leather) | 90.00 | 117.00 | | |
| Executive Low Back Swivel Chair (Black Leather) | 80.00 | 104.00 | | |
| Executive Low Back Swivel Chair (Black Fabric) | 70.00 | 91.00 | | |
| Deluxe Executive Armchair (Black Leather) | 65.00 | 85.00 | | |
| High Back Bar Stool (Black & Silver) | 75.00 | 97.00 | | |
| High Back Swivel Stool (Black or Silver) | 65.00 | 85.00 | | |
| Upholstered Arm Chair (Black) | 45.00 | 58.00 | | |
| Upholstered Side Chair (No Arms) | 40.00 | 52.00 | | |
| COMPLIMENTS (See Also Custom Accessories Sheet) | | | | |
| 2' x 8' Grid Panels - Black Chrome White | 30.00 | 39.00 | | |
| Plexi Glass Ballot Box | 30.00 | 39.00 | | |
| Tripod Easel - Black 6' tall | 18.00 | 23.00 | | |
| Bag Holder - Chrome | 45.00 | 58.00 | | |
| Waste Paper Basket | 15.00 | 20.00 | | |

COMPANY: _____
 CONTACT: _____
 BOOTH #: _____

SUB-TOTAL

12 % HST

TOTAL

**STANDARD RATES WILL BE APPLIED
 TO ALL ORDERS NOT RECEIVED AND
 PAID IN FULL PRIOR TO:
 AUGUST 8, 2011**

**YOUR COMPLETED CREDIT
 CARD AUTHORIZATION FORM
 MUST ACCOMPANY THIS
 ORDER FORM.**











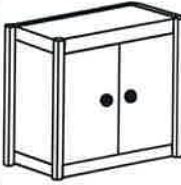
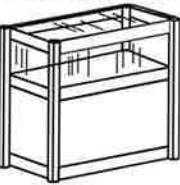

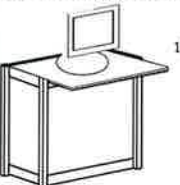
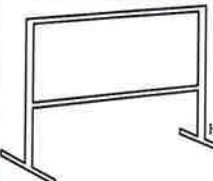
SHOW **IN** Motion

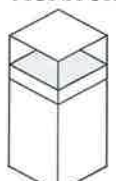
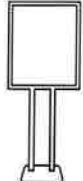
TELEPHONE: (250) 495-5025
 FACSIMILE: (250) 495-5026

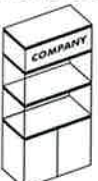

MERCHANDISE SHOW

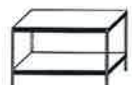
CUSTOM ACCESSORIES LEASE ORDER FORM

| | | | |
|---|--|---|---|
| <p>COUNTER \$ 350 QTY. <input type="checkbox"/></p>  <p>SLIDING DOORS INSIDE SHELF 20" X 40" X 40" LOCK</p> <p>ADD \$ 25.00</p> <p><input type="checkbox"/> WHITE OR <input type="checkbox"/> BLACK</p> | <p>JEWELLERY CASE \$ 600 QTY. <input type="checkbox"/></p>  <p>ONE SHELF 20" X 40" X 70" LOCK</p> <p>ADD \$ 25.00</p> <p>HALOGEN LIGHT</p> <p>ADD \$ 50.00</p> | <p>SHOW CASE \$ 650 QTY. <input type="checkbox"/></p>  <p>TWO SHELVES 20" X 40" X 70" LOCK</p> <p>ADD \$ 25.00</p> <p>HALOGEN LIGHT</p> <p>ADD \$ 50.00</p> | <p>COMPUTER COUNTER \$ 400 QTY. <input type="checkbox"/></p>  <p>10" KEYBOARD TRAY SLIDING DOORS INSIDE SHELF 20" X 40" X 40" LOCK</p> <p>ADD \$ 20.00</p> |
| <p>POSTER BOARD \$ 150</p>  <p>4' X 8' VERTICAL OR HORIZONTAL (SHOWN)</p> | <p>CHROME BAG HOLDER \$ 45</p>  | <p>LITERATURE RACK \$ 80</p>  <p>BLACK DOUBLE SIDED</p> | <p>MONITOR STAND \$ 300</p>  <p><input type="checkbox"/> 20" X 20" X 40" <input type="checkbox"/> 20" X 20" X 54" <input type="checkbox"/> OPTIONAL KEYBOARD TRAY AVAILABLE</p> <p>ADD \$ 25.00</p> |
| <p>SIGN HOLDER \$ 30</p>  <p>22" X 28" CHROME <input type="checkbox"/> OR BLACK <input type="checkbox"/></p> | <p>TRACK LIGHTING</p>  <p><input type="checkbox"/> 3 HEAD - \$ 120 <input type="checkbox"/> 5 HEAD - \$ 150</p> | <p>TOWER COMBO \$ 350</p>  <p>2 SHELVES INSIDE SHELF 20" X 40" X 96" COMPANY NAME OR PRODUCT SIGN INCLUDED</p> | <p>SHELF UNITS</p>  <p><input type="checkbox"/> 2 SHELVES 26" \$125 <input type="checkbox"/> 3 SHELVES 40" \$150 <input type="checkbox"/> 4 SHELVES 54" \$175</p> |
| <p>BROCHURE RACK \$ 15</p>  <p><input type="checkbox"/> 4" X 9" OR <input type="checkbox"/> 9" X 11" <input type="checkbox"/> COUNTER TOP <input type="checkbox"/> WALL MOUNT</p> | <p>BAR FRIDGE \$ 175</p>  <p>1.7 CUBIC FEET WHITE</p> | <p>END TABLE \$ 65</p>  <p>BLACK & GLASS <input type="checkbox"/> GUN METAL & GLASS <input type="checkbox"/></p> | <p>COFFEE TABLE \$ 85</p>  <p>BLACK & GLASS <input type="checkbox"/> GUN METAL & GLASS <input type="checkbox"/></p> |

SPECIAL INSTRUCTIONS:

| | |
|--------------------------------|--|
| SUB-TOTAL | |
| STANDARD RATE (ADD 30%) | |
| 12 % HST | |
| TOTAL | |

COMPANY: _____
 CONTACT: _____
 BOOTH #: _____

STANDARD RATES WILL BE APPLIED TO ALL ORDERS NOT RECEIVED AND PAID IN FULL PRIOR TO: AUGUST 8, 2011

YOUR COMPLETED CREDIT CARD AUTHORIZATION FORM MUST ACCOMPANY THIS ORDER FORM.

SHOW **IN** Motion

TELEPHONE: (250) 495-5025
FACSIMILE: (250) 495-5026



MERCHANDISE SHOW

HARD WALL PACKAGES LEASE ORDER FORM

WE CAN ALSO CUSTOM DESIGN ANY SIZE OF RENTAL EXHIBIT TO SUIT YOUR SPECIFIC REQUIREMENTS. PLEASE CALL US FOR FURTHER INFORMATION.

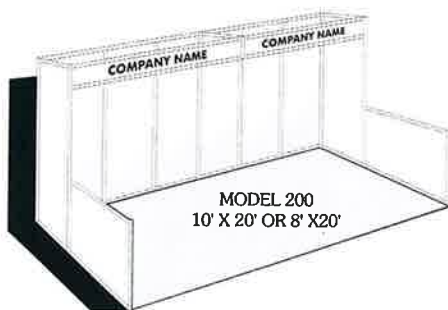
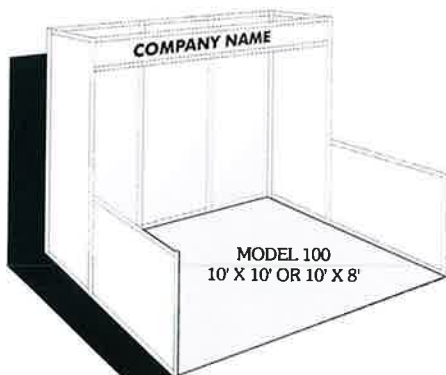

FEATURES;

- HARDWALL BACKWALLS & STEPDOWN SIDEWALLS
- BLACK, WHITE, SILVER OR BLUE PANELS (CIRCLE PREFERENCE)
- SILVER, BLUE OR GREEN CARPET (CIRCLE PREFERENCE)
- 1 COMPANY OR PRODUCT NAME SIGN (UP TO 15 CHARACTERS) (2 WITH MODEL 200)
- 1- 30" DIAMETER TABLE (2 WITH MODEL 200)
- 2 UPHOLSTERED CHAIRS (4 WITH MODEL 200)
- 1 TROPICAL PLANT (2 WITH MODEL 200)
- 1 WASTEBASKET (2 WITH MODEL 200)
- 3 - 150 WATT FLOODLIGHTS (6 WITH MODEL 200) POWER INCLUDED

| | DISCOUNT RATE | STANDARD RATE | AMOUNT |
|--------------------------------------|---------------|---------------|--------|
| MODEL 100 BOOTH PACKAGE | \$ 1100.00 | \$ 1425.00 | |
| MODEL 200 BOOTH PACKAGE | \$ 1400.00 | \$ 1820.00 | |
| MODEL 100 SHELL ONLY - NO FURNITURE | \$ 900.00 | \$ 1170.00 | |
| MODEL 200 SHELL ONLY - NO FURNITURE | \$ 1200.00 | \$ 1560.00 | |
| AVAILABLE OPTIONS | | | |
| SLOTWALL PANELS - SILVER ONLY | \$ 75.00 EA. | \$ 98.00 EA. | |
| PEGBOARD PANELS - WHITE ONLY | \$ 50.00 EA. | \$ 65.00 EA. | |
| SHELVES - WHITE OR BLACK - 10" X 39" | \$ 25.00 EA. | \$ 33.00 EA. | |
| ADDITIONAL LETTERS FOR FASCIA SIGN | \$ 2.00 EA. | \$ 2.60 EA. | |

FASCIA SIGN COPY - 15 CHARACTERS INCLUDED IN BOOTH PRICES

| |
|-----------|
| NO CHARGE |
|-----------|

SUB-TOTAL

12 % HST

TOTAL

COMPANY: _____

CONTACT: _____

BOOTH #: _____

**STANDARD RATES WILL BE APPLIED TO ALL ORDERS NOT RECEIVED AND PAID IN FULL PRIOR TO:
AUGUST 8, 2011**

YOUR COMPLETED CREDIT CARD AUTHORIZATION FORM MUST ACCOMPANY THIS ORDER FORM.

**POP-UP DISPLAY
LEASE ORDER FORM**

TABLETOP DISPLAY

\$ 350 - DISCOUNT RATE
\$ 455 - STANDARD RATE

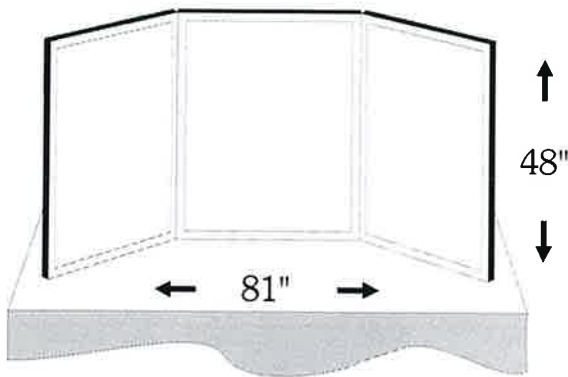

GREEN SILVER RED

VELCRO PANELS WITH 2 LIGHTS
INSTALLATION INCLUDED

POP-UP BOOTH

\$ 700 - DISCOUNT RATE
\$ 910 - STANDARD RATE

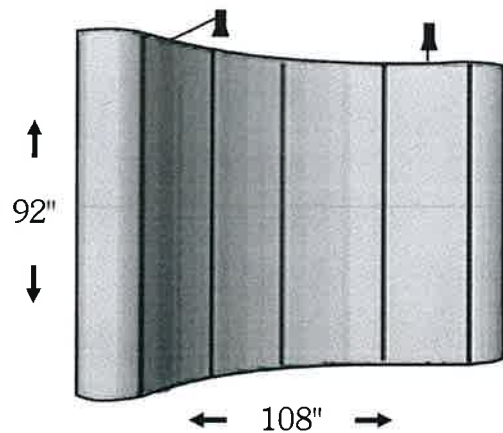

BLACK SILVER BLUE

VELCRO PANELS WITH 2 LIGHTS
INSTALLATION INCLUDED

SPECIAL INSTRUCTIONS:

SUB-TOTAL

12 % HST

TOTAL

COMPANY: _____
CONTACT: _____
BOOTH #: _____

**STANDARD RATES WILL BE APPLIED
TO ALL ORDERS NOT RECEIVED AND
PAID IN FULL PRIOR TO:
AUGUST 8, 2011**

**YOUR COMPLETED CREDIT
CARD AUTHORIZATION FORM
MUST ACCOMPANY THIS
ORDER FORM.**



**MERCHANDISE
SHOW**

**TELEPHONE: (250) 495-5025
FACSIMILE: (250) 495-5026**

**PLANTS & FLOWERS
ORDER FORM**

| ITEM | QUANTITY | DISCOUNT RATE | STANDARD RATE | AMOUNT |
|-----------------------------|----------|-------------------|---------------|--------|
| Crysanthemums | | \$ 60.00 | \$ 78.00 | |
| White Yellow Lavender | | | | |
| Boston Ferns | | \$ 70.00 | \$ 91.00 | |
| Ivy | | \$ 70.00 | \$ 91.00 | |
| Azaleas | | \$ 70.00 | \$ 91.00 | |
| 3' - 4' Tropical Plants | | \$ 90.00 | \$ 117.00 | |
| 4' - 5' Tropical Plants | | \$ 100.00 | \$ 130.00 | |
| 6' Tropical Plants | | \$ 120.00 | \$ 156.00 | |
| 7' Plus Tropical Plants | | Priced On Request | | |
| Hanging Plants | | \$ 50.00 | \$ 65.00 | |
| Small Floral Arrangements | | \$ 100.00 | \$ 130.00 | |
| Large Floral Arrangements | | \$ 150.00 | \$ 195.00 | |

ALL PLANTS INCLUDE DECORATIVE CONTAINERS, WATERING AND DELIVERY TO YOUR BOOTH
TROPICAL PLANTS WILL BE CHOSEN FROM THE FOLLOWING VARIETIES; ARECA

SUB-TOTAL

12 % HST

TOTAL

COMPANY: _____
CONTACT: _____
BOOTH #: _____

**STANDARD RATES WILL BE APPLIED TO ALL ORDERS NOT RECEIVED AND PAID IN FULL PRIOR TO:
AUGUST 8, 2011**

YOUR COMPLETED CREDIT CARD AUTHORIZATION FORM MUST ACCOMPANY THIS ORDER FORM.



TELEPHONE: (250) 495-5025
 FACSIMILE: (250) 495-5026



MERCHANDISE
 SHOW

**ELECTRICAL & LIGHTING
 ORDER FORM**

| ELECTRICAL SERVICES - POWER | PRICE | PRICE | QUANTITY | AMOUNT |
|---|--------------|---------------|----------|--------|
| | Pre-Deadline | Standard Rate | | |
| 120 Volt, 1500 Watts, 12 Amp Single Outlet | 150.00 | 195.00 | | |
| 120 Volt, 1500 Watts (24 hour service) | 200.00 | 260.00 | | |
| 120 Volt, 2000 Watts, NEMA 5-20 Plug | 200.00 | 260.00 | | |
| 120 Volt, 3000 Watts, NEMA 5-30 Plug | 250.00 | 325.00 | | |
| 208 Volt, 15 Amp, Single Phase Service | 350.00 | 455.00 | | |
| 208 Volt, 20 Amp, Single Phase Service | 400.00 | 420.00 | | |
| 208 Volt, 30 Amp, Single Phase Service | 450.00 | 585.00 | | |
| 208 Volt, 60 Amp, Single Phase Service | 700.00 | 910.00 | | |
| 208 Volt, 15 Amp, Three Phase Service | 450.00 | 585.00 | | |
| 208 Volt, 20 Amp, Three Phase Service | 500.00 | 650.00 | | |
| 208 Volt, 30 Amp, Three Phase Service | 650.00 | 845.00 | | |
| 208 Volt, 60 Amp, Three Phase Service | 800.00 | 1040.00 | | |
| Tie-In Service, Additional Labor Charge. 1 Hour Minimum Install. 1/2 Hour Minimum Dismantle. Monday - Friday: 8:00 AM - 4:00 PM | 70.00/HR. | 91.00/HR. | | |

SEE ATTACHED FORM FOR
 TERMS & CONDITIONS

TO RECEIVE ADVANCE
 PRICES FULL PAYMENT
 MUST ACCOMPANY
 YOUR ORDER AND BE
 RECEIVED PRIOR TO
 THE DEADLINE DATE
 NOTED ABOVE.

FOR A DEDICATED
 CIRCUIT OR 24 HOUR
 SERVICE DOUBLE THE
 OUTLET RATE PRICE.

ELECTRICITY WILL BE
 TURNED ON WITHIN
 30 MINUTES OF SHOW
 OPENING AND OFF
 WITHIN 30 MINUTES
 AFTER SHOW CLOSING.

IF YOU REQUIRE
 HIGHER VOLTAGES,
 WATTAGES OR SPECIAL
 LIGHTING, PLEASE CALL
 FOR A QUOTE.

THERE IS A MINIMUM
 LABOR CHARGE OF
 1.5 HOURS FOR
 ALL TIE-IN SERVICES
 AND ANY SERVICE
 REQUIRING 208 VOLT
 OR HIGHER SERVICES.

LABOR RATES:
 MONDAY - FRIDAY
 (EXCEPT HOLIDAYS)
 8:00 AM - 4:00 PM
 \$ 70.00 / HOUR
 ALL OTHER HOURS
 \$ 90.00 / HOUR

IT IS YOUR RESPONSIBILITY
 TO SUPPLY AN APPROVED
 GFCI PROTECTION DEVICE
 FOR ANY SERVICE PROVIDED
 FOR USE TO A HOT TUB.

ISLAND BOOTHS
 A SCALED FLOORPLAN
 MUST ACCOMPANY ALL
 ORDERS SHOWING
 LOCATION OF
 ELECTRICAL OUTLETS,
 CONNECTIONS AND
 LIGHTING EQUIPMENT.

PLEASE PROVIDE YOUR REQUIRED RECEPTACLE INFORMATION

Straight Blade Twist Lock Tie-In

| LIGHTING SERVICES | | | | |
|---|-------|-------|--|--|
| Double Head Light Unit On Stand - 150 Watts | 60.00 | 78.00 | | |
| Triple Head Light Unit On Stand - 150 Watts | 70.00 | 91.00 | | |
| Arm Bar Light Unit - 75 Or 150 Watts | 40.00 | 52.00 | | |
| Triple Head Extension Cord | 20.00 | 26.00 | | |
| Power Bar / Surge Suppressor | 30.00 | 39.00 | | |

SUB-TOTAL

12 % HST

TOTAL

COMPANY: _____

CONTACT: _____

BOOTH #: _____

STANDARD RATES WILL BE APPLIED
 TO ALL ORDERS NOT RECEIVED AND
 PAID IN FULL PRIOR TO:
AUGUST 8, 2011

YOUR COMPLETED CREDIT
 CARD AUTHORIZATION FORM
 MUST ACCOMPANY THIS
 ORDER FORM.

COMMONLY ASKED QUESTIONS

HOW MUCH POWER DO I NEED?

1. Calculate the power for your lighting needs by totalling the wattage of your lights.
2. For other equipment, read the rating from on the back or bottom of the unit (see example). The plate will tell you the amperage or wattage, voltage and phase requirements. Power must be ordered according to peak amperage ratings.

120V 1 PH = 120 Volt - Single Phase
60 Hz = 60 Cycle
1000 W = 1000 Watts

208V 1 PH = 208 Volt
30A = 30 Amp
3PH = Three Phase

WHERE WILL MY POWER BE LOCATED?

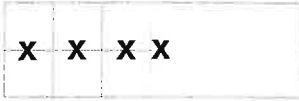

INLINE BOOTHS - PENINSULA



BACK TO BACK PENINSULAS

A scaled floorplan must accompany orders showing location of electrical outlets, connections and lighting.

ISLAND BOOTHS

RULES & REGULATIONS

1. Order (with payment) must be received prior to the deadline date noted on the front of this form in order to receive the advance pricing. Orders faxed or mailed without payment will not guarantee advance prices, payment must be received as well. All orders received after the deadline date will be priced at Standard rates.
2. In the event that the totals calculated on the reverse of this form are not correct, Show In Motion reserves the right to make any necessary corrections.
3. Outlet rates listed include bringing the service to one location at the rear of all inline, peninsula booths and is brought to one location in all island booths. Show In Motion will make every attempt to deliver power to island booths to a location convenient to the exhibitor.
4. Outlet rates listed do not include include tie-in service. Additional tie-in services, special wiring, distribution of electrical services, or labor are not included. Distribution from the power source to all other locations inside a booth space, regardless of booth type, requires labor, and is done on a time and material basis. Exhibitors are invited to contact Show In Motion to discuss any additional costs that may be incurred.
5. A separate outlet must be ordered for each location where electricity is required. "Daisy Chaining" extension cords together is in contravention of the both the BC Safety Authority and Canadian Electrical Code and is not permitted.
6. Labor rates shown on the Electrical & Lighting form are based on current wage scales and are subject to change in the event of wage changes prior to your event. A minimum charge of one (1) hour labor will apply for the installation and one half (1/2) hour will apply for the dismantle.
7. Show In Motion employees are permitted to cut floor coverings when essential for the installation of services unless specifically instructed otherwise.
8. All material and equipment furnished by Show In Motion is done on a rental basis ONLY and remains at all times the property of Show In Motion. It shall be removed only by Show In Motion staff.
9. If you have ordered power bars and / or extension cords and do not find them in your booth upon your arrival please come to our service desk to pick them up.
10. Standard wall and other permanent facility utility outlets or sockets are not part of your booth space and may not be used by exhibitors unless authorized by Show In Motion staff. Standard charges will apply.
11. All equipment, regardless of source of power, must comply with the Canadian Electrical Code, the Electrical Safety Act and be CSA approved. Show In Motion is authorized to refuse to supply power and or connections where the exhibitor supplied wiring or equipment is not in accordance with the above noted regulations.
12. All electrical equipment must be properly tagged and wired with complete information as to type of current required for operation, voltage, phase, cycle, horsepower, etc.
13. All exhibitors power cords must be a minimum of 14 gauge, 3 wire and grounded. Two wire extension cords are not permitted. All exposed non-current carrying metal parts of fixed equipment which are liable to be energized must be grounded.
14. Credit will not be given for services installed and not used.
15. Claims will not be considered or adjustments made unless filed in writing by the exhibitor prior to the close of the event.
16. Exhibitor holds Show In Motion harmless for any and all losses of power beyond Show In Motion's control including, but not limited to, losses due to utility company failure, permanent power distribution failure, power failure caused by vandalism, faulty exhibitor equipment or overloads caused by any exhibitor.
17. It is agreed that in the event it becomes necessary to turn any legal matter over to an attorney for settlement the Exhibitor will pay Show In Motion for it's legal fees or applicable agency fees.

IF YOU HAVE ANY QUESTIONS, PLEASE CALL (250) 495-5025